

SERIE

R

2024_LINE_1



Cilindri a corsa breve

Short stroke cylinders



CARATTERISTICHE TECNICHE - TECHNICAL CHARACTERISTICS

Pressione di esercizio <i>Working pressure</i>	1 ÷ 10 bar (doppio effetto - <i>double acting</i>) 2 ÷ 10 bar (semplice effetto - <i>single acting</i>)
Temperatura di esercizio <i>Working temperature</i>	0 ÷ +80 °C (-20 °C con aria secca - <i>with dry air</i>)
Versioni - Versions	semplice effetto (molla anteriore) - <i>single acting (front spring)</i> doppio effetto - <i>double acting</i>
Alesaggi - Bores	∅ 8 - 12 - 20 - 32 - 50 - 63
Corse - Strokes	vedere tabelle corse standard - <i>see standard stroke tables</i>
Fluido - Fluid	aria compressa filtrata, non lubrificata - <i>compressed filtered, non lubricated air</i>

CARATTERISTICHE COSTRUTTIVE - CONSTRUCTIVE CHARACTERISTICS

①	Stelo - Rod	acciaio inox AISI 303 - <i>stainless steel AISI 303</i>
②	Guarnizione - Seal	poliuretano - <i>polyurethane</i>
③	Boccola - Bush	∅ 8 - 12 - 20 ottone - <i>brass</i> ∅ 32 - 50 - 63 acciaio + PTFE - <i>steel+PTFE</i>
⑥	Testata - Cover	∅ 8 - 12 - 20 ottone - <i>brass</i> ∅ 32 - 50 - 63 alluminio anodizzato - <i>anodized aluminium</i>
④	Boccola - Bush	acciaio+PTFE - <i>steel+PTFE</i>
⑤	O-ring	NBR
⑦	Tubo - Tube	alluminio anodizzato - <i>anodized aluminium</i>
⑧	Guarnizione - Seal	NBR
⑨	Pistone semplice effetto <i>Piston single acting</i>	∅ 8 - 12 acciaio inox AISI 303 - <i>stainless steel AISI 303</i> ∅ 20 alluminio - <i>aluminium</i> ∅ 32 - 50 - 63 delrin - <i>delrin</i>
⑨	Pistone doppio effetto <i>Piston double acting</i>	∅ 12 - 20 alluminio - <i>aluminium</i> ∅ 32 - 50 - 63 delrin - <i>delrin</i>
	Molla - Spring	acciaio - <i>steel</i>

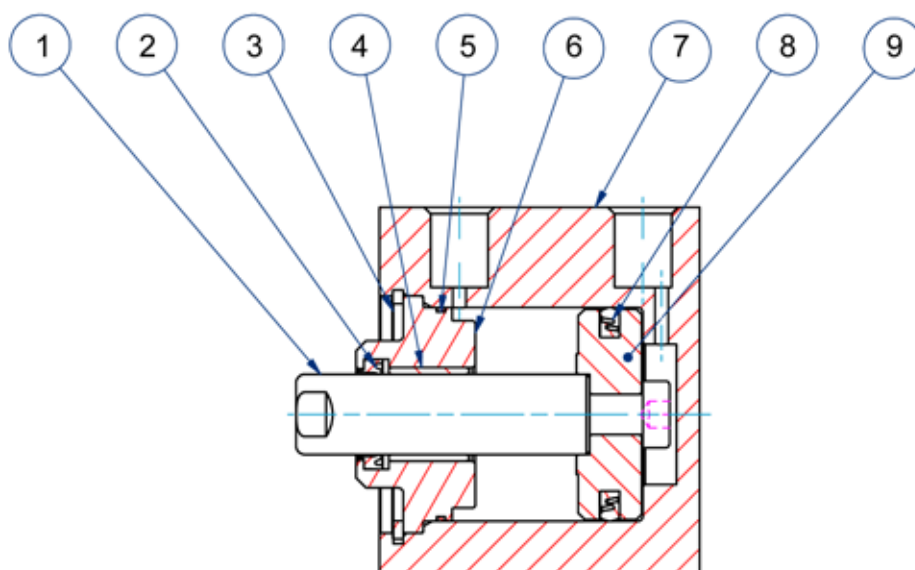

CHIAVE DI CODIFICA

KEY CODE

R	D	0	1	2	.	0	1	0	.	G	S	.	M
		ALESAGGIO - BORE (Ø)			CORSA - STROKE (mm)						STELO - ROD		
		008 - 012 - 020 032 - 050 - 063			vedere tabelle corse std see std stroke tables						F femmina female M maschio male L liscio smooth		
		VERSIONE - VERSION									GUARNIZIONI - SEALS		
		S semplice effetto molla anteriore single acting front spring									GS guarnizioni standard standard seals		
		D doppio effetto double acting											
		SERIE - SERIES											
		R barra piena di alluminio aluminium solid bar											

SERIE
R

FORZE TEORICHE MINIME DELLE MOLLE

RS

THEORETICAL MINIMUM SPRING FORCES

	FORZA TRAZIONE [N] TRACTION FORCE [N]	FORZA DI BLOCCAGGIO [N] LOCKING FORCE [N]	CARICO MAX [g] MAX LOAD [g]
RS008.004.GS.L	3,2	25	-
RS012.004.GS.L	5	55	25
RS012.010.GS.L	7	53	25
RS020.004.GS.F	7	170	75
RS020.010.GS.F	15	160	75
RS020.025.GS.F	13	157	75
RS032.005.GS.F	28	454	100
RS032.010.GS.F	23	459	100
RS032.025.GS.F	21	461	100
RS050.010.GS.F	53	1080	200
RS050.025.GS.F	49	1075	200
RS063.010.GS.F	67	1765	250
RS063.025.GS.F	73	1735	250

FORZE TEORICHE DI TRAZIONE (P=6bar)

RD

THEORETICAL FORCES OF TRACTION (P=6bar)

		Ø	012	020	032	050	063
RD	SPINTA THRUST	[N]	68	189	483	1.178	1.870
	TRAZIONE TRACTION	[N]	51	141	415	1.056	1.750

SEMPLICE EFFETTO - MOLLA ANTERIORE

SINGLE ACTING - FRONT SPRING

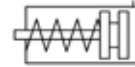
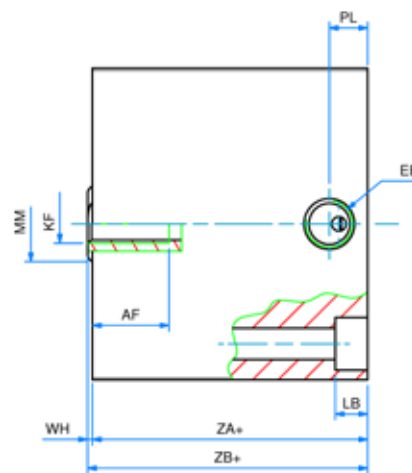
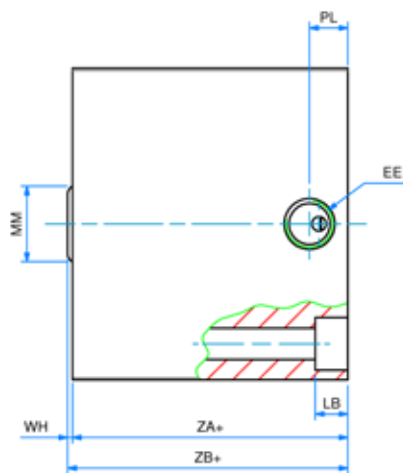
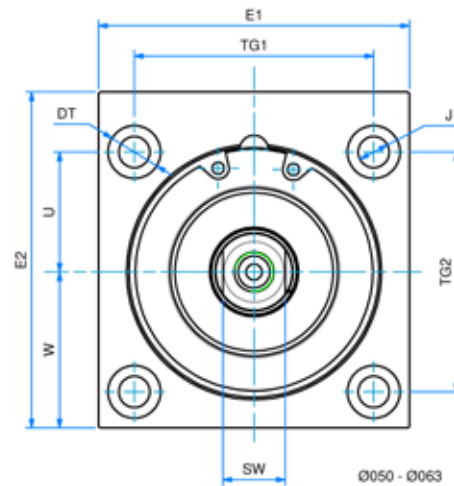
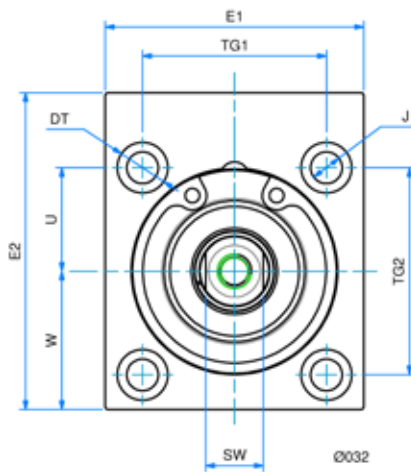
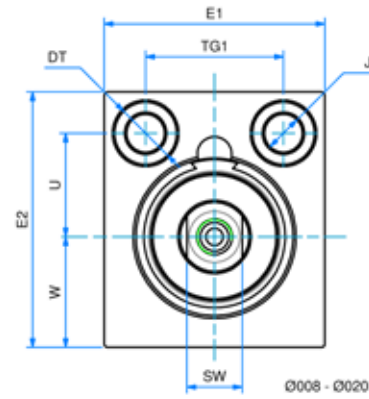
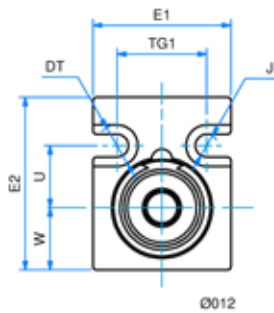
 SERIE
R

SEMPLICE EFFETTO - MOLLA ANTERIORE
SINGLE ACTING - FRONT SPRING

DIMENSIONI - DIMENSIONS							
COD.	RS008.004.GS.L	RS012.004.GS.L	RS012.010.GS.L	RS012.010.GS.F	RS020.004.GS.F	RS020.010.GS.F	RS020.025.GS.F
AF	-	-	-	10	9	10	10
DT	6	6	6	6	9	9	9
E1	18	20	20	20	32	32	32
E2	20	25	25	25	37	37	37
EE	M5	M5	M5	M5	M5	M5	M5
KF	-	-	-	M3	M5	M5	M5
LB	3,1	3,4	3,4	3,4	5,5	5,5	5,5
MM	4	5	5	5	10	10	10
J	3,4	3,3	3,3	3,3	5,5	5,5	5,5
PL1	5,5	6	6	6	5	5	5
SW	-	-	-	-	8	8	8
TG1	11	13	13	13	20	20	20
TG2	-	-	-	-	-	-	-
U	8	9	9	9	15	15	15
W	6,5	9	9	9	16	16	16
WH	1	1	4	4	1	1	1
ZA+	12	12	16	16	16	22	28
ZB+	13	13	20	20	17	23	29

DIMENSIONI - DIMENSIONS							
COD.	RS032.005.GS.F	RS032.010.GS.F	RS032.025.GS.F	RS050.010.GS.F	RS050.025.GS.F	RS063.010.GS.F	RS063.025.GS.F
AF	10	14,5	14,5	10,5	15,5	14,5	14,5
DT	8,8	8,8	8,8	11	11	14	14
E1	45	45	45	65	65	80	80
E2	55	55	55	70	70	85	85
EE	G1/8	G1/8	G1/8	G1/8	G1/8	G1/8	G1/8
KF	M6	M6	M6	M8	M8	M8	M8
LB	5,7	5,7	5,7	6,8	6,8	9	9
MM	12	12	12	16	16	16	16
J	5,5	5,5	5,5	6,5	6,5	9	9
PL1	8,5	8,5	8,5	7,5	8	8	8
SW	10	10	10	13	13	13	13
TG1	32	32	32	50	50	62	62
TG2	36	36	36	50	50	62	62
U	18	18	18	25	25	31	31
W	24	24	24	32,5	32,5	40	40
WH	1	1	1	1	1	1	2
ZA+	21	22	32,5	20	32,5	25	35,5
ZB+	22	23	33,5	21	33,5	26	37,5

+ = aggiungere lunghezza corsa (mm) - add stroke length (mm)

STELI STANDARD - STANDARD PISTON RODS							
Ø	008	012	020	032	050	063	
FEMMINA - FEMALE		X	X	X	X	X	
MASCHIO - MALE							X
LISCIO - SMOOTH	X	X					

Ø CORSE STANDARD - STANDARD STROKES	
008	4
012	4 - 10
020	4 - 10 - 25
032	5 - 10 - 25
050	10 - 25
063	10 - 25

DOPPIO EFFETTO

DOUBLE ACTING



SERIE
R

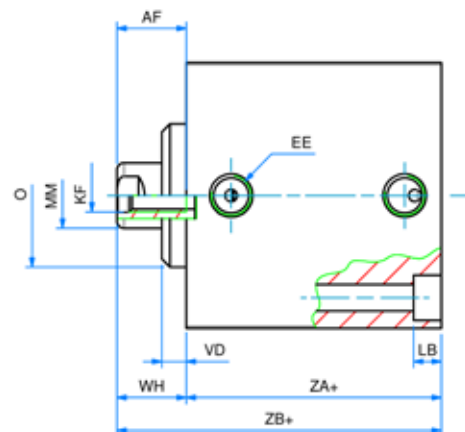
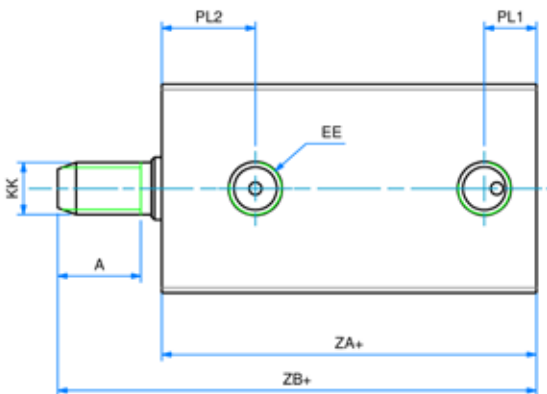
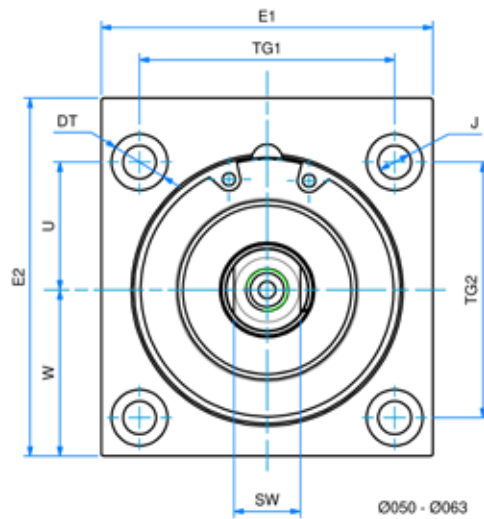
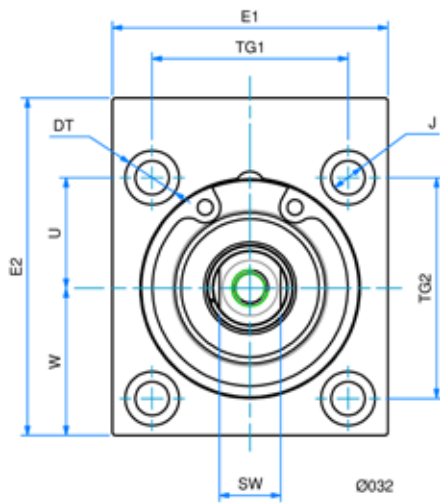
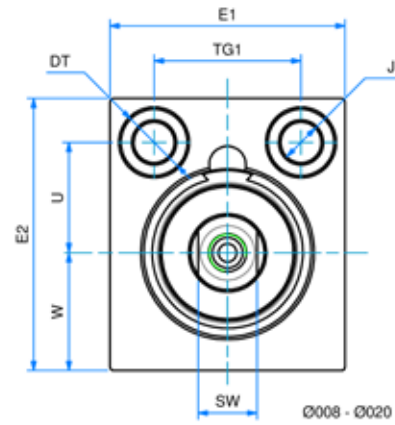
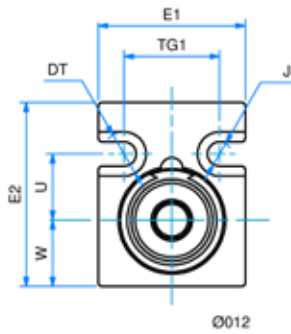

DOPPIO EFFETTO
DOUBLE ACTING

DIMENSIONI - DIMENSIONS					
Ø	012	020	032	050	063
A	9	-	-	-	-
AF	-	10	15	17	17
Ø DT	6	9	9,5	11	14
E1	20	32	45	65	80
E2	25	37	56	70	85
EE	M5	M5	G1/8	G1/8	G1/8
KF	-	M5	M6	M8	M8
KK	M5	-	-	-	-
LB	3,4	5,5	5,7	6,8	9
Ø MM	6	10	12	16	16
Ø J	3,3	5,5	5,3	6,5	9
Ø O	-	-	22	35	35
PL1	5	5	8,5	9	8
PL2	9	8,5	12	11	13
SW	-	8	10	13	13
TG1	13	20	32	50	62
TG2	-	-	36	50	62
U	9	15	18	25	31
VD	-	-	3,5	6	6,5
W	9	16	24	32,5	40
WH	1	9,5	12,5	17	17
ZA+	21	24,5	33	32,5	35,5
ZB+	31	34	45,5	49,5	52,5

+ = aggiungere lunghezza corsa (mm) - add stroke length (mm)

STELI STANDARD - STANDARD PISTON RODS					
Ø	012	020	032	050	063
FEMMINA - FEMALE		X	X	X	X
MASCHIO - MALE	X				
LISCIO - SMOOTH					

Ø	CORSE STANDARD - STANDARD STROKES
012	5 - 10 - 15 - 20 - 25 - 30
020	5 - 10 - 15 - 20 - 25 - 30
032	5 - 10 - 15 - 20 - 25 - 30
050	5 - 10 - 15 - 20 - 25 - 30
063	5 - 10 - 15 - 20 - 25 - 30



Realized and distributed by
Triveneta automazioni s.r.l.
via Carlo Rosselli, 36 - 36061 Bassano del Grappa (VI)
tel. 0424/505152 - fax 0424/505189

www.triveneta.it - www.t3components.com
amministrazione@triveneta.it
sales.manager@triveneta.it
info@t3components.com





TRIVENETA AUTOMAZIONI s.r.l.

Tel. 0424 505152 - Fax 0424 505189

info@t3components.com

www.t3components.com